



CORROSION CONTROL



SensorGuard

'INTELLIGENT PROTECTION FOR LIGHTNING EVENTS'

Benefits

SensorGuard has been designed to provide the highest level of protection for sensitive electronic devices and power supply systems from the threats of fluctuations in the AC power system, surge events caused by direct lightning strikes and ground potential rise (GPR) due to ground strikes.

SensorGuard can deliver significant operational and capital expenditure savings to your company, through:

- **Reduction in system downtime:** **SensorGuard** works by automatically disconnecting the equipment from the power supply BEFORE lightning induced surges occur; thereby isolating the equipment from the cause of damage.
- **Reduction in capital costs incurred due to equipment damage:** By removing connection to the power supply and DC output, the site equipment will not be damaged by lightning induced surges. This could include uninterrupted power supply (UPS) systems which are there to provide a back up supply upon loss of mains power.
- **Reduced maintenance costs:** The reduced level of equipment damage will require fewer maintenance hours and technician visits.

The Product

The surest method of protecting any electrical or electronic device from a surge event is to simply disconnect the pathway by which voltage and current flows into and out of a circuit or device. This principle has been used for many years at large data centres where switch over to back up power and then disconnection from the power supply is carried out upon warning of storm activity from a weather forecasting service.

SensorGuard operates on a similar principle, with on site lightning prediction, and can provide open line isolation between the protected device and metallic conductors at a fraction of the cost. Being small and versatile it can be fitted in almost any location, thereby providing cost effective, high level protection to almost any electronic or electrical equipment.

How it Works

SensorGuard consists of two integral components: the central control module which controls the power, monitors the power grid and activates the power interrupt circuit; and the lightning sensor which is fiber optically linked to the control module.

SensorGuard automatically provides open line isolation BEFORE a surge occurs. It is activated by sensing any of the following conditions:

- Fluctuations in the AC power system (high voltage stress)
- Surge events caused by direct lightning strikes
- GPR due to ground strikes

Upon detection of a surge event the central control module controls a contactor which will provide the open line isolation to the protected equipment (both AC & DC). The open line isolation to the protected equipment will present an extremely high resistance to any surge causing the voltage and current to follow the path of least resistance provided by surge protection devices or ground earthing.

SensorGuard then continues to monitor the threat and maintains the open line isolation until no further strike or power anomaly events are detected. The power to the protected equipment will then be automatically restored by the central control module closing the contactor.

Features

- Continually monitors AC power for instability. Monitors for threatening atmospheric conditions (lightning ground strike activity).
- Eliminates damage due to unstable power and peak load demand conditions.
- Eliminates fault current pathways through sensitive electronic circuits.
- Pro-active 'isolation' approach will complement all Surge Protection Devices
- Rugged design assures dependable protection in any environment.
- Optional 'Plug-N-Play' or 'Hard Wired' configuration.
- Low maintenance modular design for 'in field' service & upgrading.
- Ideally suited for a wide range of protection applications.
- Complies to International IEC Safety Standards.
- Can be fitted into a suitably rated enclosure depending on site location.

Operation

To demonstrate how **SensorGuard** protects sensitive electronic equipment, data logging equipment was used to provide a direct comparison of supply side voltage and the voltage passed through by **SensorGuard**. The system was set up as shown below.

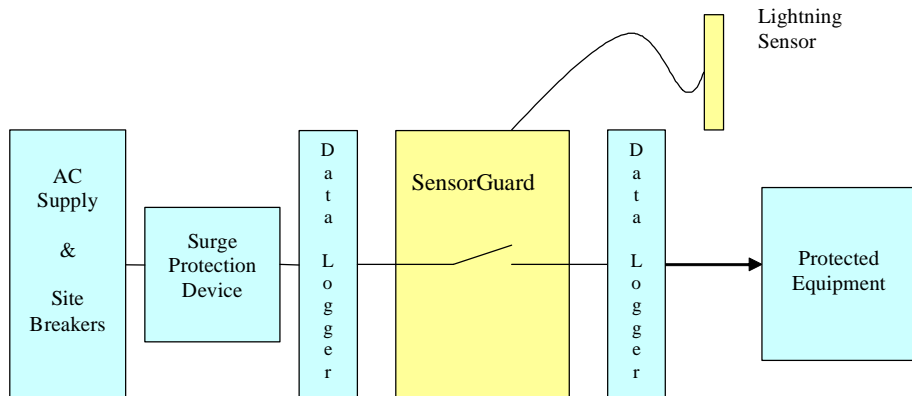

The resulting data shows how **SensorGuard** isolated the protected equipment from the AC supply when lightning activity or supply fluctuation was detected.

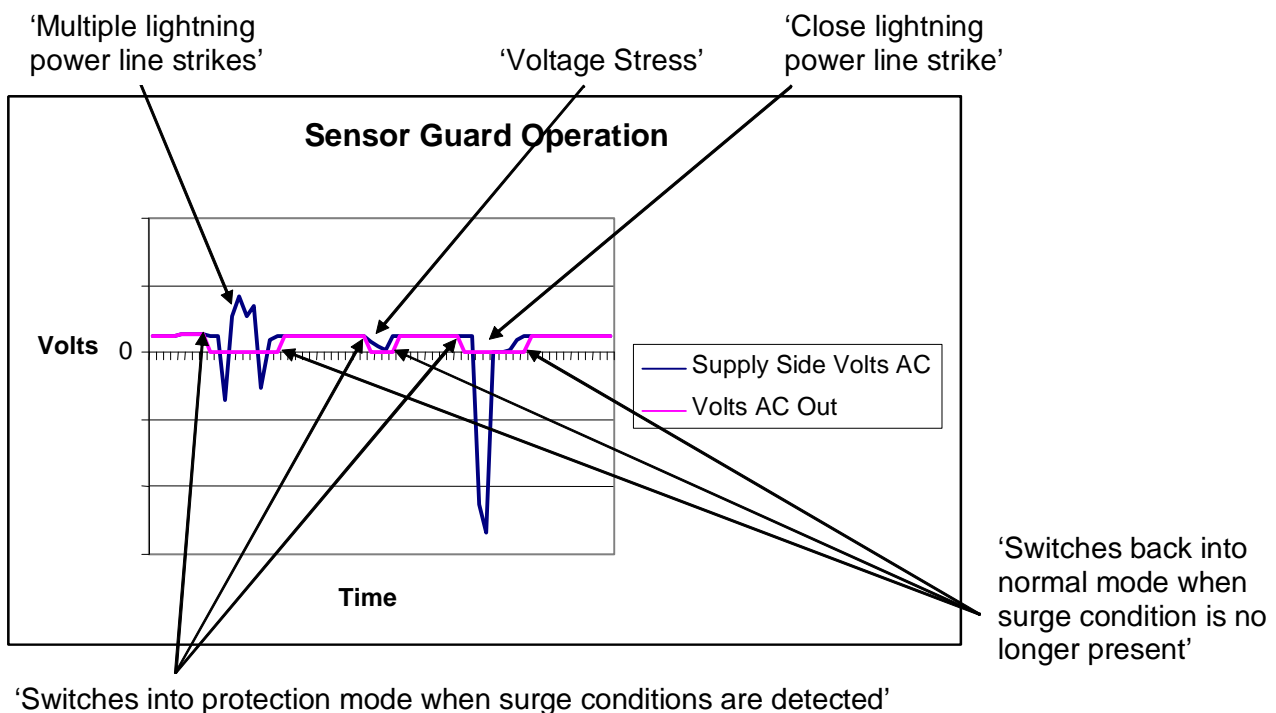



CORROSION CONTROL

BAC CORROSION CONTROL LTD
Stafford Park 11, Telford, Shropshire, TF3 3AY UK
Tel +44 (0) 1952 290321
Fax +44 (0) 1952 290325
Email: sales@bacgroup.com
Website: www.bacgroup.com

